

DIMENSIONS AND SPECIFICATIONS

Product	Magicow 6
Machine Identification	Model #: FC2613 Version #: EG6X14BE
Machine Weight	85lbs
Shipping Weight	91lbs
Shipping Dimensions	30.5"L x 19"W x 42"H (77.47cm L x 48.26cm W x 106.68cm H)
Refrigeration	134A Refrigerant, CFC Free, Compressor Cold Air Evaporation
Overload Protection	Time Delay Circuit Breaker, 120 VAC, 15 Amps
Product Capacity	2/2.5 Gallons (9.46 Liters)
Voltage	110/120 VAC, 60 Hz
BTU	1023
Power Consumption	13 Amp Startup, 2 Amp Running
Cabinet Material	Polyethylene FR Additive
Certifications	NSF/ANSI Standard 20, UL 471

Electrical requirements: Requires dedicated electrical connection; 110/120 VAC, Single Phase, 60 Hz, 15 Amp

Space Requirements:

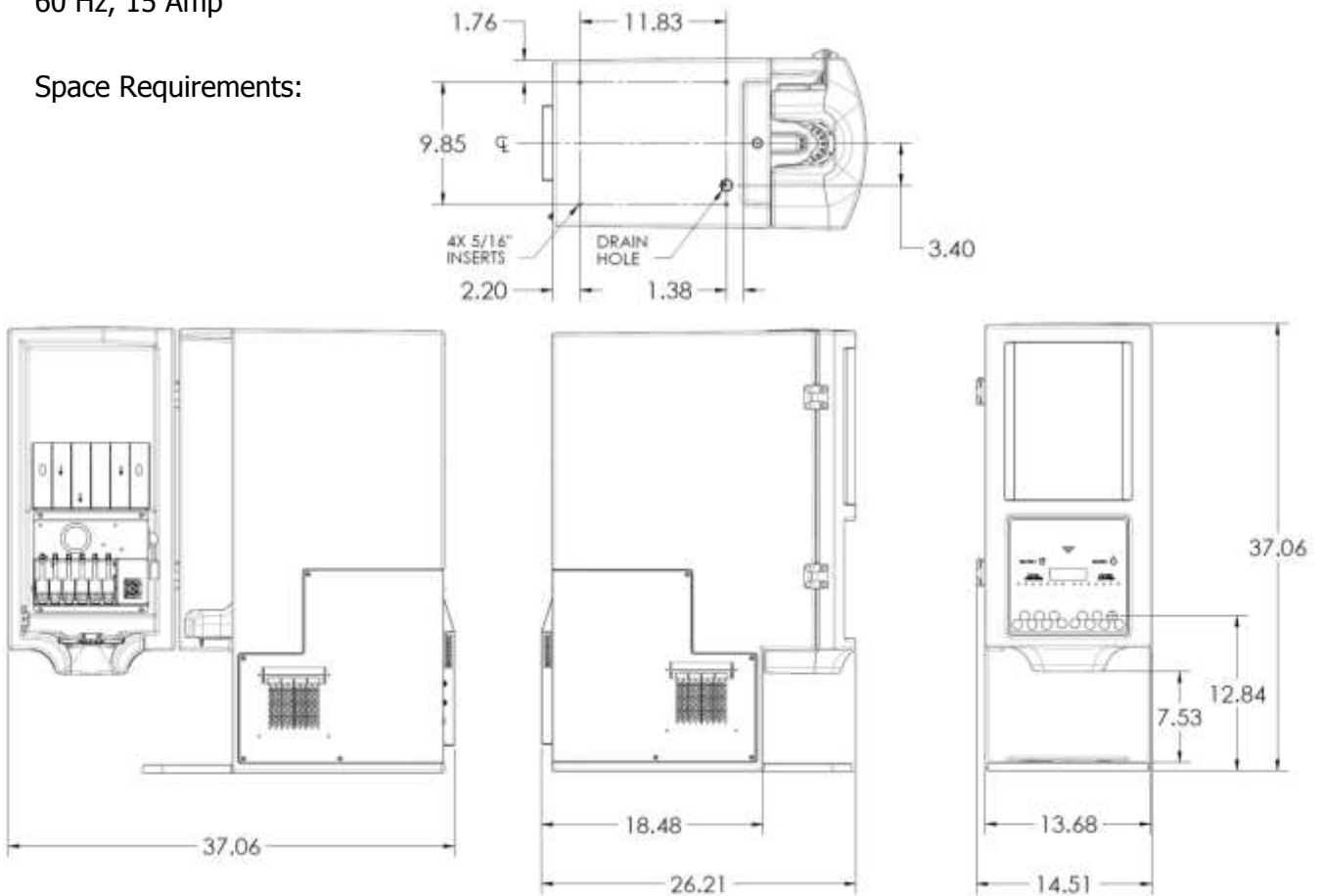

Note: Please allow an additional 6" clearance behind the unit to facilitate proper cooling and air circulation.

EIEIO, Inc – 1615 Rutherford Lane Austin, TX 78754 • 800-513-4346 • www.eieio-inc.com

EIEIO, Inc practices continuous product research and improvement. We reserve the right to change specifications and product design without notice. Such revisions do not entitle the buyer to corresponding changes, improvements, or replacement of any previously purchased equipment.